

M2703 SERIES

3-PHASE AC/DC POWER SUPPLY



PRODUCT HIGHLIGHTS

- 3-PHASE AC/DC POWER SUPPLY
- HIGH EFFICIENCY
- SINGLE OUTPUT
- UP TO 2.5 kW

Applications

Military, Ruggedized, Telecom, Industrial Power Supply

Special Features

- Compact size
- High efficiency
- Wide input range
- Input / Output isolation
- Fixed switching frequency (approx. 400 kHz)
- Logic Inhibit
- EMI filters included
- Limited Inrush Current
- Indefinite short circuit protection with auto-recovery
- Over temperature shutdown with auto-recovery

Environmental Conditions

Meets or exceeds MIL-STD-810G

Temperature:

Operating -55 °C to +85 °C (at baseplate) Storage
-55 °C to +125 °C

Reliability

150,000 hours, calculated per
MIL-STD-217F at +85 °C baseplate, Ground Fixed.

Electrical Specifications

AC INPUT

Nominal voltage:

3-Phase 115 V_{RMS,L-N} ± 6% / 400 Hz

Input Transient Protection:

Meets MIL-STD-704F abnormal transients. Efficiency:
90%, Typical

Power Factor: Minimum 85% from 50% load

EMC: Designed to meet MIL-STD-461F CE102, CS101,
CS114, CS115, CS116, RE102, RS101,
RS103 with external filter and shielded cable. Isolation:
Input to Output: 500 V_{DC}
Input to Case: 500 V_{DC}

DC OUTPUT (floating)

Voltage range: 100 to 320 V_{DC} Current range: no load up
to 20 A

Line/Load regulation: Less than ±1% (0 to 100% load, -
55 °C to +85 °C)

Ripple and Noise: 100 mV_{p-p}, typical (max. 1%) Current
limiting:

Continuous protection for unlimited time

Over-voltage protection:

Passive tranzorb on output. Over temperature
protection:

Shutdown if baseplate temperature exceeds
+105 °C ± 5 °C; Automatic recovery upon
baseplate cooldown to below +95 °C ± 5 °C

Isolation:

Output to Case: 5

M2703 SERIES 3-PHASE AC/DC POWER SUPPLY

Pin Assignment

CONNECTOR J2 (INPUT)

Connector type: M24308/24-38F or eq.
Mating connector: M24308/2-2F or eq.

Function	Pin No.
PHASE A	7, 14, 15
PHASE B	4, 5, 12
PHASE C	2, 9, 10
CHASSIS	1

CONNECTOR J1 (OUTPUT)

Connector type: M24308/23-38F or eq.
Mating connector: M24308/4-2F or eq.

Function	Pin No.	Polarity
V_{OUT}	4, 5, 11, 12	+
V_{OUT} RTN	7, 8, 14, 15	-
INHIBIT	3	+
INHIBIT RTN	2	-
PWR GOOD	10	+
PWR GOOD RTN	13	-

Functions and Signals

INHIBIT signal (connector J1, pin 3)

The **INHIBIT** signal is used to turn the power supply ON and OFF. To turn the power supply ON, leave pin 3 open.

To turn the power supply OFF, short pin 3 to pin 2.

If not used, leave pin 3 unconnected.

This signal is referenced to **INHIBIT RTN (connector J1, pin 2)**

PWR GOOD signal (connector J1, pin 10)

The **PWR GOOD** signal indicates the status of the output voltage.

When output voltage rises above $95\% \pm 5\%$ of its nominal value, pin 10 will be pulled down to pin 13 through a $49.9 \Omega \pm 1\%$ resistor and a phototransistor.

When output voltage falls below $90\% \pm 5\%$ of its nominal value, pin 10 will be in high impedance mode. If not used, leave the signal unconnected.

This signal is referenced to **PWR GOOD RTN (connector J1, pin 13)**

Both pins 10 and 13 are isolated from all other parts of the circuitry.

Typical Connection Diagram

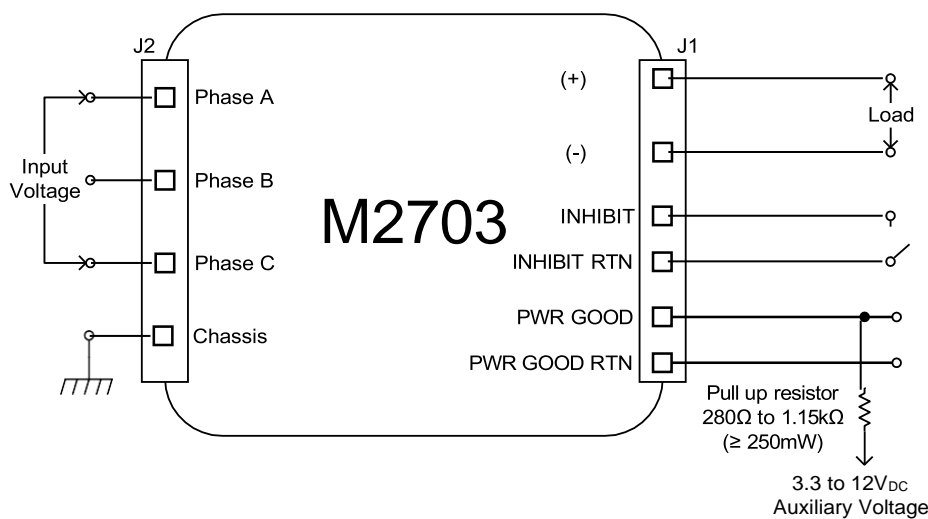

Note: PWR GOOD pull-up resistor and auxiliary voltage shown in this diagram are typical values. The system designer must select the actual values such that no damage can occur to the internal components of the power supply – *consult factory for more information.*

M2703 SERIES 3-PHASE AC/DC POWER SUPPLY

Outline Drawing

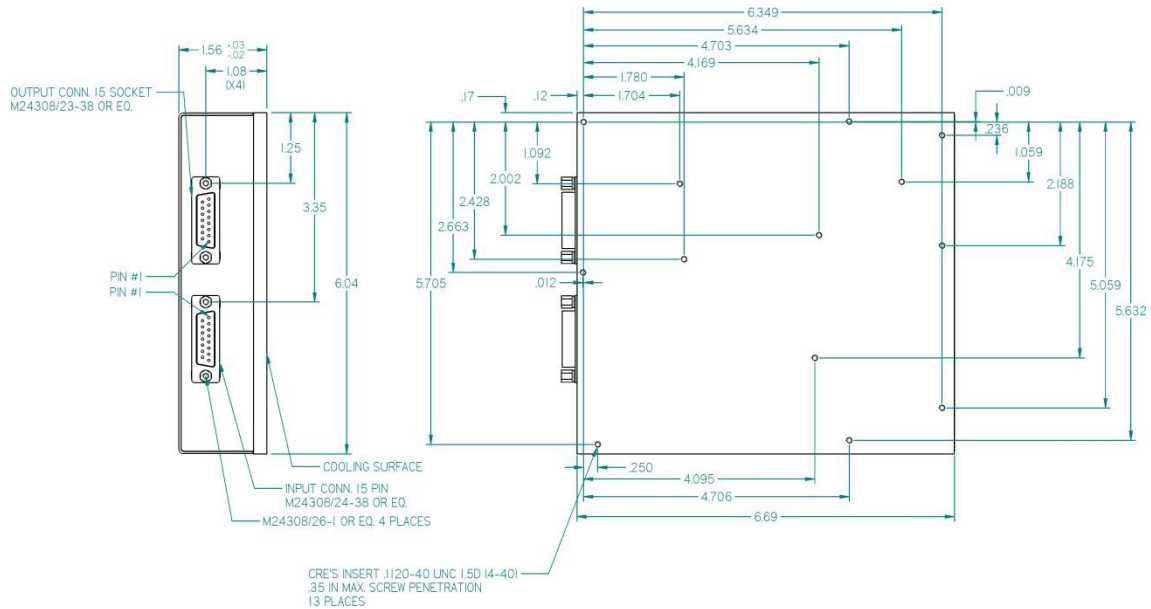

Heat Dissipation Surface Area

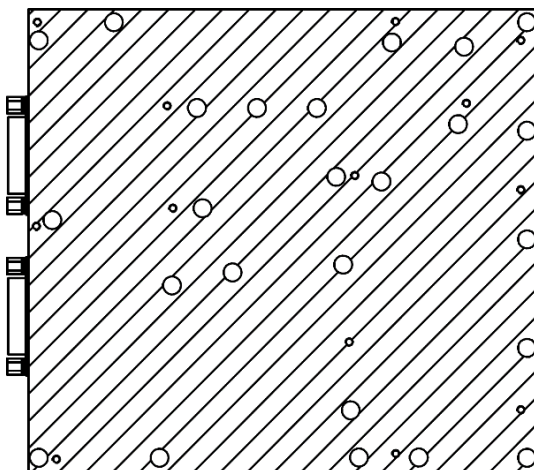

Surface area:
39.2 sq. in.
[25 290 sq. mm]

Notes

1. Dimensions are in Inches
2. Tolerance is:
.XX ±.02 IN
.XXX ±.01 IN
3. Weight: Approx. 4.2 lbs. [1.9kg]

Note: Specifications are subject to change without prior notice by the manufacturer