

# M4054 SERIES

## DC/DC POWER SUPPLY

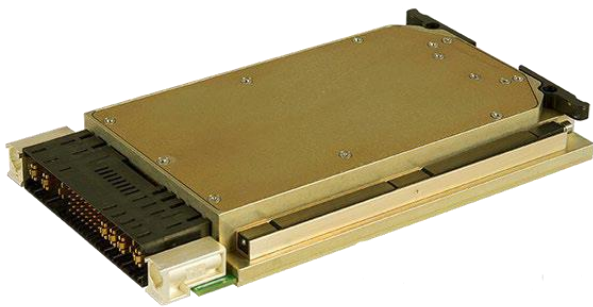

### PRODUCT HIGHLIGHTS

- VITA 62 COMPLIANT
- SOSA™ ALIGNED
- 3U FORM FACTOR
- 18 to 48VDC Standard Version Input
- UP TO 800 W
- OPERATING TEMP: –55°C to +85°C
- EMI: Compliant to MIL-STD-461G
- Environmental: MIL-STD-810
- Input Options:
  - MIL-STD-704
  - MIL-STD-1275
  - DEF-STAN 61-5
- Cyber secure

## **SPECIAL FEATURES**

- VITA 62 Compliant
- Aligned with the SOSA™ Technical Standard
- Wide input range
- Up to 800W output power<sup>1</sup>
- Remote sense
- Fixed switching frequency (220 kHz)
- External synchronization capability
- Indefinite short circuit Protection
- Over-voltage shutdown with auto-recovery
- Reverse battery protection
- Over temperature shutdown with auto-recovery
- EMI filters included.
- System Management: protocol per VITA 46.11
  - Output voltages and currents
  - Input voltage
  - Card temperature
  - Card system status

1. Operation under 22V input at full load may exceed connector pins maximum current rating.

## ***Electrical Specifications***

### **DC Input**

18 to 48V<sub>DC</sub> standard  
Max Non-Operation 100Vdc  
Options:

- 1) MIL-STD-704 (A-F) Normal and Abnormal Steady State
- 2) MIL-STD-704(A-F) transients Up to 50V, 80V.
- 3) MIL-STD-704 (A-F) Transients Under 18V and Starting transients
- 4) MIL-STD-1275 Surges

### **DC Output**

PO1 (VS1): 12V up to 32A PO3 (VS1): 12V up to 32A  
PO2 (3.3VAux): 3.3V up to 15A

### **Current Sharing**

12V A.C.S  
3.3Vaux P.C.S (A.C.S optional)

### **Efficiency**

Up to 91.5 % (see Para.4)

### **Isolation**

Over 20 MΩ at test voltage: 200V between Input and Output 200V between Input and Case 100V between Output and Case

### **EMC**

Qualified to:

MIL-STD-461G<sup>1</sup> CE101, CE102, CS101, CS114, CS115, CS116

### **Line/Load regulation**

#### **Ripple and Noise**

Typically, less than 50mV<sub>p-p</sub> (max. 1%<sub>o-p</sub>). Measured across a 0.1μF capacitor and 10μF capacitor on load at Input Voltage of 18V-36V, all Temperature Range.

#### **Load Transient Overshoot and Undershoot**

##### **Undershoot**

Output dynamic response of less than 5% at load Step of 30%-60%. Output returns to regulation in less than 1mSec

#### **System management options:**

- 1) I2C
- 2) IPMI
- 3) VITA 46.11 Tier I IPMC (Tier 3 Expected by January 2020)

Data available:

- Output voltages and currents
- Input voltage
- Card temperature
- Card status

#### Notes:

1. Compliance achieved with 5μH LISN and static resistive load.

***Environmental*** <sup>1</sup>

Design to Meet MIL-STD-810G

**Temperature**

Operating: -55°C to +85°C at unit edge  
Storage: -55°C to +125°C

**Altitude**

Method 500.5, Procedure I & II  
Storage/Air Transport: 40 kft  
Operation/Air carriage: 70 kft

**Salt Fog:**

Method 509.5

**Fungus**

Does not support fungus growth, in accordance with the guidelines of MIL-STD-454, Requirement 4.

**Humidity**

Method 507.5, Up to 95%

**Shock**

Method 516.6  
40g, 11msec saw-tooth (all directions)

**Vibration**

Vibration: Figure 514.6E-1. General minimum integrity exposure. (1 hour per axis.)

**Reliability: 481,000 Hours, calculated IAW MIL-HDBK-217F Notice 2 at +65 °C, GF.**

Note 1: **Environmental Stress Screening (ESS)** Including random vibration and thermal cycles is also available. **Please consult factory for details.**

***Protections*** <sup>1</sup>

**Input**

**Output**

**General**

• **Over Temperature Protection**

Automatic shutdown at internal temperature of 95 ± 5°C.  
Automatic recovery when temperature drops below 90 ± 5°C.

*Functions and Signals - According to VITA 62*

Signal Name	Type	Description
FAIL*	Output	Indicates to other modules in the system that a failure has occurred in one of the outputs. Please refer to Figure 2 <sup>1</sup>
SYSRESET*	Output	Indicates to other modules in the system that all outputs are within their working level. Please refer to Figure 2 <sup>1</sup>
INHIBIT*	Input	Controls power supply outputs. This signal in conjunction with <b>ENABLE</b> controls the outputs. Please refer to Table 1 and Figure 1 <sup>1</sup>
ENABLE*	Input	Controls power supply outputs. This signal in conjunction with <b>INHIBIT</b> controls the outputs. Please refer to Table 1 and Figure 1 <sup>1</sup>
GA0*, GA1*, GA2*	Input	Used for geographical addressing. GA2 is the most significant bit and GA0 is the least significant bit. <sup>1</sup>
SCL, SDA	Bidirectional	I2C bus Clock and Data respectively. Through this bus the voltage and temperature readouts can be shared. <sup>1</sup>
SCL_B, SDA_B	Bidirectional	Redundant I2C bus Clock and Data respectively. Through this bus the voltage and temperature readouts can be shared. <sup>1</sup>
REF_CLK	Input	The REF_CLK signal is used to allow the power supply frequency to sync with the system frequency. <sup>1</sup> Optional.
VOUT SENSE	Input	The SENSE is used to achieve accurate load regulations at load terminals (this is done by connecting the pins directly to the load's terminals).
Alert Bit	Output	Indicates to other modules in the system about Input Voltage loss. Please refer to Figure 2 <sup>1</sup> (Optional, non-SOSA configuration)
3.3Vaux A.C.S	Bidirectional	Support 3.3Vaux Active current share between Outputs. See Current Share para. <sup>1 2 3</sup> (Optional, non-SOSA configuration)
PO#_SHARE	Bidirectional	Support current share between Outputs <sup>1</sup>

Notes:

1. Signal referenced to **SIGNAL RTN**.
2. When not used leave open.
3. For 3.3Vaux In Passive or Non-Current Share configuration, this pin is Internally Disconnected.

Table 1 – Inhibit and Enable Functionality

<b>INHIBIT*</b>	<b>Low</b>	<b>Low</b>	<b>High</b>	<b>High</b>
<b>ENABLE*</b>	<b>Low</b>	<b>High</b>	<b>Low</b>	<b>High</b>
<b>VS1</b>	OFF	OFF	ON	OFF
<b>3.3V</b>	ON	OFF	ON	OFF

Figure 1 – Inhibit and Enable Input stage

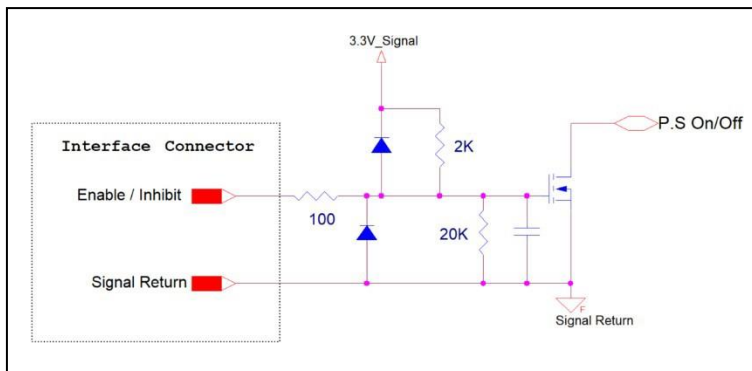
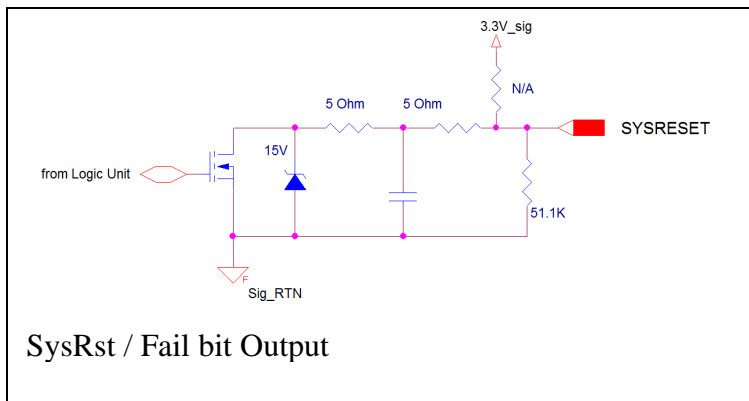

Figure 2 – SysRst and Fail bit Output Stage





## Detailed Information

### 1. M4054 Input Voltage Operation.

The M4054 steady state operation voltage is 18V to 48V and will continuously work up to 50V/80V Input line. When configured to support MIL-STD 704/1275 transients or surges, the unit will shut down when input voltage rises above 60V or Under 16V for more than 2Sec and immediate shut down under 12V or above 100V Input. Power supply automatically recover when Input goes back to normal steady state line.

**Please Note:** Working at steady state low line under 22V may exceed connector 40A current limitation. Unit can be calibrated to work steady state or to be limited by TBD Sec to support Input transients during low line.

Note: 1275E configuration is optional, contact Factory.

#### 1.1. Steady state Low Line Turn-on and Turn-off Limits

To avoid Turn-on and Turn-off glitch the unit have about 2V Hysteresis. The Turn-on threshold is under 20V and turn- off under 18V.

Those limits can be adjusted, contact Factory for more information.

### 2. Outputs Voltage Regulation

The M4054 contains accurate internal sense lines to keep output voltage at less than 4% regulation for all Line/ Load and temperature range (see Table 2).

Output	12V/64A	3.3V/15A
Voltage Range	11.85 - 12.15	3.28 - 3.42

Table 2: Outputs voltage regulation. VIN 18V to 48V, Temperature -55 to 85 °C

#### 2.1. Sense Lines

*Sense Lines* are provided for VS1, VS2 and VS3 output to compensate line voltage drop. *Sense Lines* proper connection is shown in Figure 3.

Each VSx output has its own *Sense Lines*, additional common *Sense RTN Line* is provided for all VSx Outputs (VITA 62 Standard).

Contact Factory for Sense configuration different than the VITA 62 standard

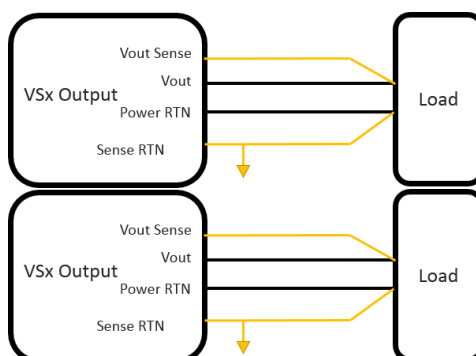

Figure 3: M4054 Sense line connection

### 3.Current Share (C.S)

Current Share of two or more units is optional (Contact Factory)

12V output and 3.3VAux will current share with about 2-4A load balance.

#### 3.1. Active current sharing (A.C.S)

Current sharing done in a closed loop. All paralleled outputs are compared and feedback is used to balance their load current. The result is a more stable, less sensitive output voltage without voltage drop. Typical Load Balance of about 2-4A for all Load range is expected. ACS is supported by the 12V output. Optional for 3.3Vaux<sup>1 2</sup>.

#### 3.2. Vaux Passive Current Sharing (P.C.S).

Current sharing is done in open loop, output voltage drops as a function of output load. Load Balance of about 5-10% is expected. 3.3 Vaux ACS is optional<sup>1 2</sup>

#### 3.3. Current share connection between two Units.

For a required output to current share please connect the following Pins between the two units

- *PO#\_Sense & PO#\_Sense\_RTN* (for best performance, Pins from paralleled units should be connected to a single point and as close as possible to the load point)
- *VS1\_SHARE (A7, C7)*
- *3.3Vaux\_SHARE (B7)*
- *3.3Vaux\_ACS (B4)* Optional<sup>1 2</sup>

Typical ACS Dynamic Load of Two 12V Paralleled Outputs (P01 & P02 refer to two different units)

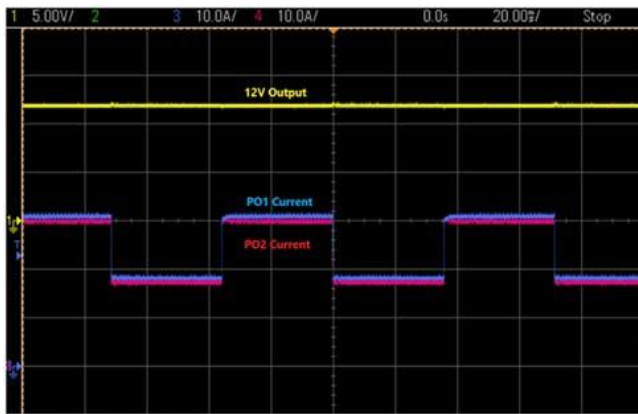

Notes:

1. When Not used, 3.3Vaux A.C.S can be left open.  
When ordering 3.3Vaux P.C.S or 3.3Vaux Non-Current Share unit, this pin is Internally disconnected
2. 3.3 Vaux ACS (Pin B4) is not supported by SOSA and is optional

### 4. Efficiency

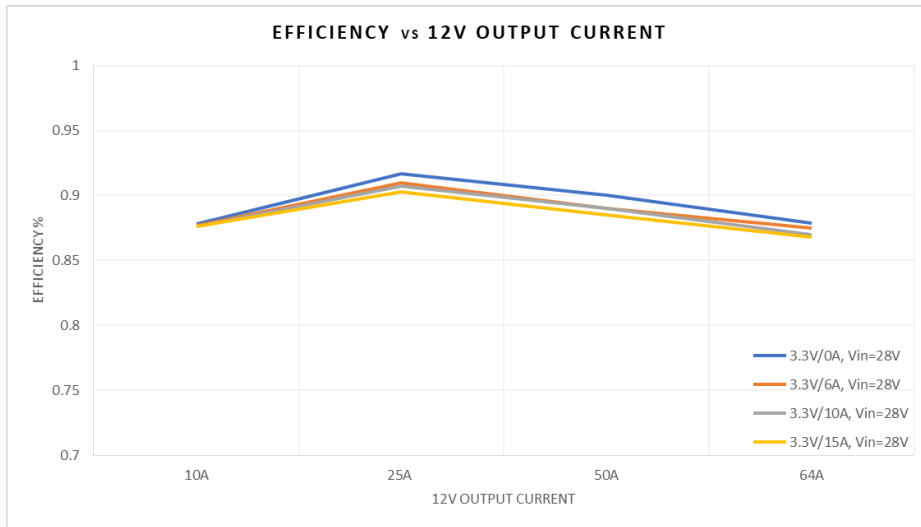

### 5. EMI CE102 Tests

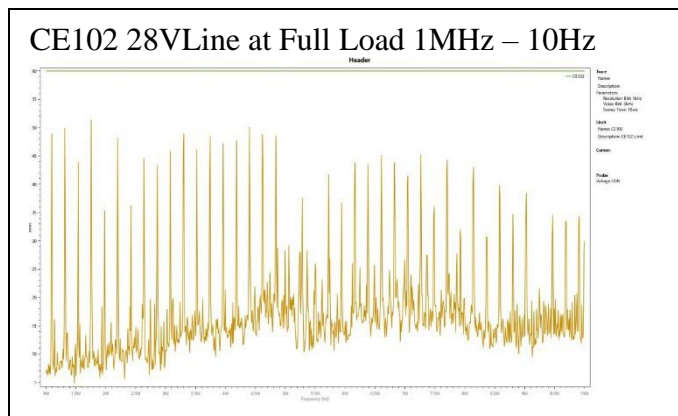
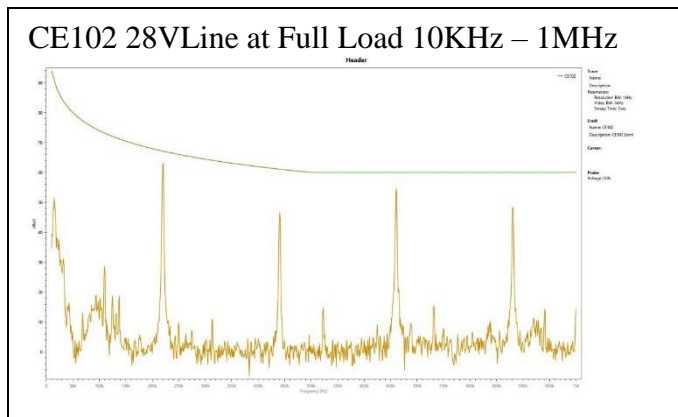

## 6.Communication Protocol

Unit communication protocol can be configured as Vita 46.11 Tier 1 IPMC or basic IPMI compatible protocol. For more details on protocols refer to para. 5.1 and 5.2

**Vita 46.11 Tier 3 IPMC is expected by January 1 2020.**

### 6.1. IPMI Protocol

#### Electrical Parameters

Vcc: 3.3VDC  
 Pull-up: 20kOhm  
 Input capacitance: 100pf

#### Slave Device Addressing

- 256 address spaces
- Baud rate: 200kHz maximum
- 7 Bit Protocol
- Support Slot Addressing per VITA 62

Slot Number	MSB							LSB
	A6	A5	A4	A3	A2/GA2*	A1/GA1*	A0/GA0*	R/W
Slot0	0	1	0	0	0	0	0	
Slot1	0	1	0	0	0	0	1	
Slot2	0	1	0	0	0	1	0	
Slot3	0	1	0	0	0	1	1	

\* Slot location is determined by GAX per VITA 62.

#### Communications Supported

Read Command – 21Hex, deliver 64Bytes of Data. (More commands are available by request) The communication starts when the master sends a start followed by the unit slave address, command, checksum and a stop. A second start followed by the slave address and a read will be followed by a 64 Bytes response.

S	Slave Address	R/W	A	Command	A	Check sum	A	P
	A6:A0	0	0	21 Hex	0	DF Hex	0	

S	Slave Address	R/	A	DATA	A	DATA	A	DATA	A	...	DATA	A	Check sum	N/A	P
	A6:A0	1	0	D7:D0	0	D7:D0	0	D7:D0	0	...	D7:D0	0	D7:D0	1	

Command – 21Hex read all 64 Bytes

S -Start  
 P- Stop

Master Transmit	Unit Transmit
-----------------	---------------

### Memory Space

Response Byte #	Data Type	Meaning	Interpretation	Reading Range
0	U Integer, MSB First	Echo of Command		21 Hex
1		N/A		00 Hex
2-3	S Integer, MSB First	Temperature -55C to 120C	T(C°)=+/- 7bit Dec	-55°C to 125°C
3		N/A		00 Hex
4-5	U Integer, MSB First	12V VS1 Voltage	V(out) = Data· m2	20.48V
6-7	U Integer, MSB First	3.3V VS2 Voltage	V(out) = Data· m2	20.48V
8-9	U Integer, MSB First	N/A	N/A	N/A
10-11	U Integer, MSB First	N/A	N/A	N/A
12-13	U Integer, MSB First	N/A	N/A	N/A
14-15	U Integer, MSB First	N/A	N/A	N/A
16-17	U Integer, MSB First	12V VS1 Current	V(out) = Data· m3	80A
18-19	U Integer, MSB First	3.3V VS2 Current	V(out) = Data· m3	20A
20-21	U Integer, MSB First	N/A	N/A	N/A
22-23	U Integer, MSB First	N/A	N/A	N/A
24-35	U Integer, MSB First	N/A	N/A	N/A
26-27	U Integer, MSB First	N/A	N/A	N/A
28-29	U Integer, MSB First	Reserved	00Hex	
30-31	U Integer, MSB First	Reserved	00Hex	
32-51	Character String (ASCII)	Part Number	M4054-xxx* (Note1)	20 Characters
52-53	Decimal, MSB First	Serial Number, 2MSB Dig	X,X Dec (Note2)	Optional
54-55	Decimal, MSB First	Serial Number, 2LSB Dig	X,X Dec (Note2)	Optional
56-57	Decimal, MSB First	Date Code	Week, Year (Note3)	Optional
58-59	Character String (ASCII)	Hardware Rev	B01 & B02 Boards (Note4)	2 Characters
60-61	Decimal, MSB First	Firmware Rev	X,X,X,X Dec (Note5)	4 digits
62	U Integer, MSB First	Reserved		AA Hex
63	U Integer, MSB First	Zero Checksum	Value required to make the sum of bytes 0 to 62 added to a multiple of 256	

#### Notes:

M2 = 20.48/65535

M3 = 80/65535

M4 = 20/65535

\*Matching unit part number

**Notes 1 to 5**

1. Part Number Example: M4465

Byte No'	32	33	34	35	36	37	38	39-51
Character	M	4	4	6	5	(-)	4	0
Hex	4D	34	34	36	35	2D	34	00

2. Serial Number Example: 25

Byte No'	52		53		54		55	
Dec Number	0	0	0	0	0	0	2	5
Binary	"0000"	"0000"	"0000"	"0000"	"0000"	"0000"	"0010"	"0101"

3. Date Code Example: week 35 of 2018

Byte No'	56		57	
Dec Number	3	5	1	8
Binary	"0011"	"0101"	"0001"	"1000"

4. Hardware Rev Example: B01 Rev (-), B01 Rev A

Byte No'	58	59
Character	(-)	A
Hex	2D	41

5. Firmware Rev Example: 2.1.0.0

Byte No'	60		61	
Dec Number	2	1	0	0
Binary	"0010"	"0001"	"0000"	"0000"

46.11 Tier 1

Please see *46.11 User Manual* for detailed information of operation.

Sensors included are seen in the table below.

Record ID	Sensor ID	Sensor Type	Name
0000	00	F0h	FRU State Sensor
0001	01	F1h	System IPMB Link Sensor
0002	02	F2h	FRU Health Sensor
0003	03	02h	FRU Voltage Sensor
0004	04	F3h	FRU Temperature Sensor
0005	05	F4h	Payload Test Results Sensor
0006	06	F5h	Payload Test Status Sensor
0100	07	02h	VS1 Voltage
0101	08	02h	VS2 Voltage
0106	0D	03h	VS1 Current
0107	0E	03h	VS2 Current
010C	13	01h	Analog Temperature
9999	N/A	N/A	Device Management

### Pin Assignment

Pin Number	Pin Name
P1	-DC_IN
P2	+DC_IN
LP1	CHASSIS
P3	VS1
P4	POWER_RETURN
P5	POWER_RETURN
LP2	3.3Vaux
P6	VS1
A8	VS1_SENSE
B8	3.3Vaux_SENSE
C8	N.C (VS1_SENSE)
D8	SENSE_RETURN
A7	VS1_SHARE
B7	3.3Vaux_SHARE
C7	VS1_SHARE
D7	SiG_RTN
A6	SCL_B
B6	SDA_B
C6	N.C.
D6	SYSRESET*
A5	GA0*
B5	GA1*
C5	SCL
D5	SDA
A4	N.C.
B4	3.3Vaux ACS/N.C
C4	N.C
D4	N.C
A3	REF CLK- / N.C
B3	N.C.
C3	N.C (NED)
D3	N.C (NED RETURN)
A2	N.C.
B2	FAIL*
C2	INHIBIT*
D2	ENABLE*
A1	REF CLK+
B1	NVMRO / N.C
C1	GA2*
D1	Alert / N.C.

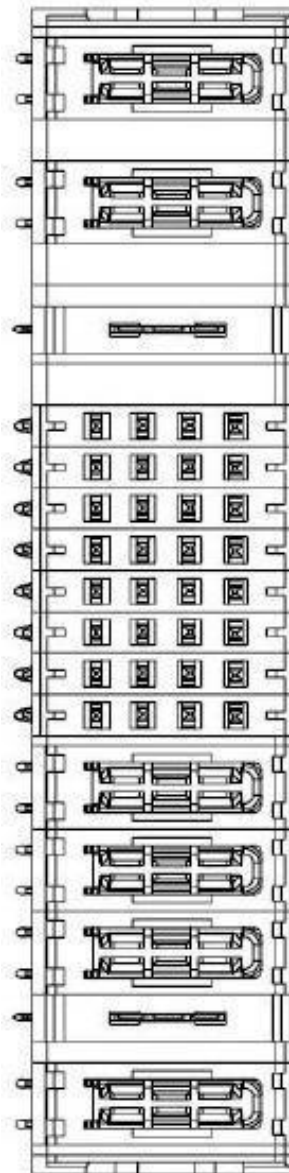

PART NUMBER 6450849-7	ROWS	POWER								SIGNAL								POWER							
		P1	P2	LP1	1		2		3		4		5		6		7		8		P3	P4	P5	LP2	P6
	D				Z5	Z5	Z5	Z5	Z5	Z5	Z5	Z5	Z5	Z5	Z5	Z5	Z5	Z5	Z5						
	C				Y5	Y5	Y5	Y5	Y5	Y5	Y5	Y5	Y5	Y5	Y5	Y5	Y5	Y5	Y5						
B	TT	TT	LT																	TT	TT	TT	LT	TT	
A				R5	R5	R5	R5	R5	R5	R5	R5	R5	R5	R5	R5	R5	R5	R5							
2ACP+1LP+3CS+3HDP+1LP+1HDP																									

**Notes:**

- Pin assigned as Function/N.C is optional and can be configured as not connected
- Alert – indicating a loss of Input voltage
- ACS – Active Current Share (for Ordering configuration, please refer to A.C.S section)

*Outline Drawing*

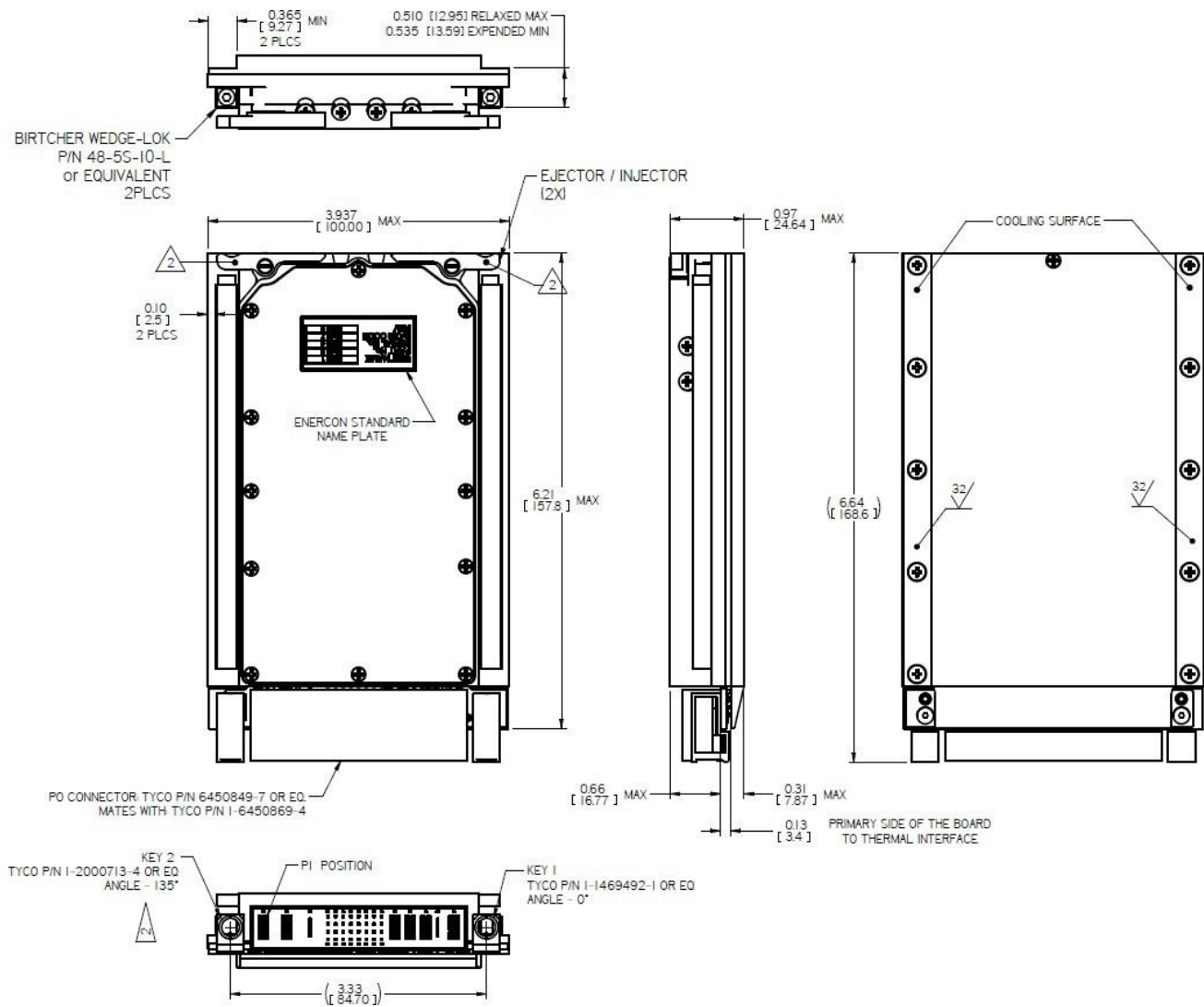

**Notes:**

1. Dimensions are in Inches[mm]
2. Tolerance is:  
.XX ± 0.02 IN  
.XXX ± 0.008 IN
3. Weight: Approx. 800 g (24.34) oz
4. 3D model available

\* Specifications are subject to change without prior notice by the manufacturer.