

M8110 SERIES

DC/DC POWER SUPPLY



PRODUCT HIGHLIGHTS

- **MINIATURE**
- **HIGH DENSITY**
- **TEN OUTPUTS**
- **DC/DC CONVERTER**
- **UP TO 150W**

APPLICATIONS

Military, Ruggedized, Telecom, Industrial

SPECIAL FEATURES

- Miniature size
- High efficiency
- Wide input range
- Input / Output isolation
- Fixed switching frequency (250 kHz)
- External synchronization capability
- TTL logic enable
- EMI filters included
- Indefinite short circuit protection with auto-recovery
- Over-voltage shutdown with auto-recovery
- Over temperature shutdown with auto-recovery

ENVIRONMENTAL CONDITIONS

Meets or exceeds MIL-STD-810D

Temperature:

Operating: -55 °C to +85 °C (baseplate)

Storage: -55 °C to +125 °C

RELIABILITY

150,000 hours, calculated IAW MIL-HDBK-217F Notice 2 at +85 °C baseplate, Ground Fix conditions.

ELECTRICAL SPECIFICATIONS

DC INPUT

Input voltage range: 18 to 48 V_{DC}

Input transient protection:

All models meet or exceed (no damage)

MIL-STD-1275A (100 V for 50 ms) and

MIL-STD-704A, MIL-STD-704D (80 V for 0.1 s)

Efficiency: up to 80%

EMC: Designed to meet MIL-STD-461F*

CE101, CE102, CS101, CS114, CS115, CS116, RE101,

RE102, RS101, RS103

Isolation:

Input to Output: 200 V_{DC}

Input to Case: 200 V_{DC}

DC OUTPUTS (floating from input)

Line/Load regulation:

Typical ±1% (for low voltages up to ±4%)

(no load to full load, -55 °C to +85 °C)

Ripple and Noise: 50 mV_{p-p} typical (max. 1%)

Current limiting:

Continuous protection for unlimited time

Over voltage protection:

Passive transorb on outputs

Over temperature protection:

Shutdown if baseplate temperature exceeds +105 ±

5 °C. Automatic recovery upon cooldown to below

+95 ± 5 °C.

Isolation:

Output to Case: 100 V_{DC}

* EMC compliance achieved when tested with 5 μH

LISNs, shielded harness and static resistive load

OPERATIONAL BLOCK DIAGRAM TYPE A

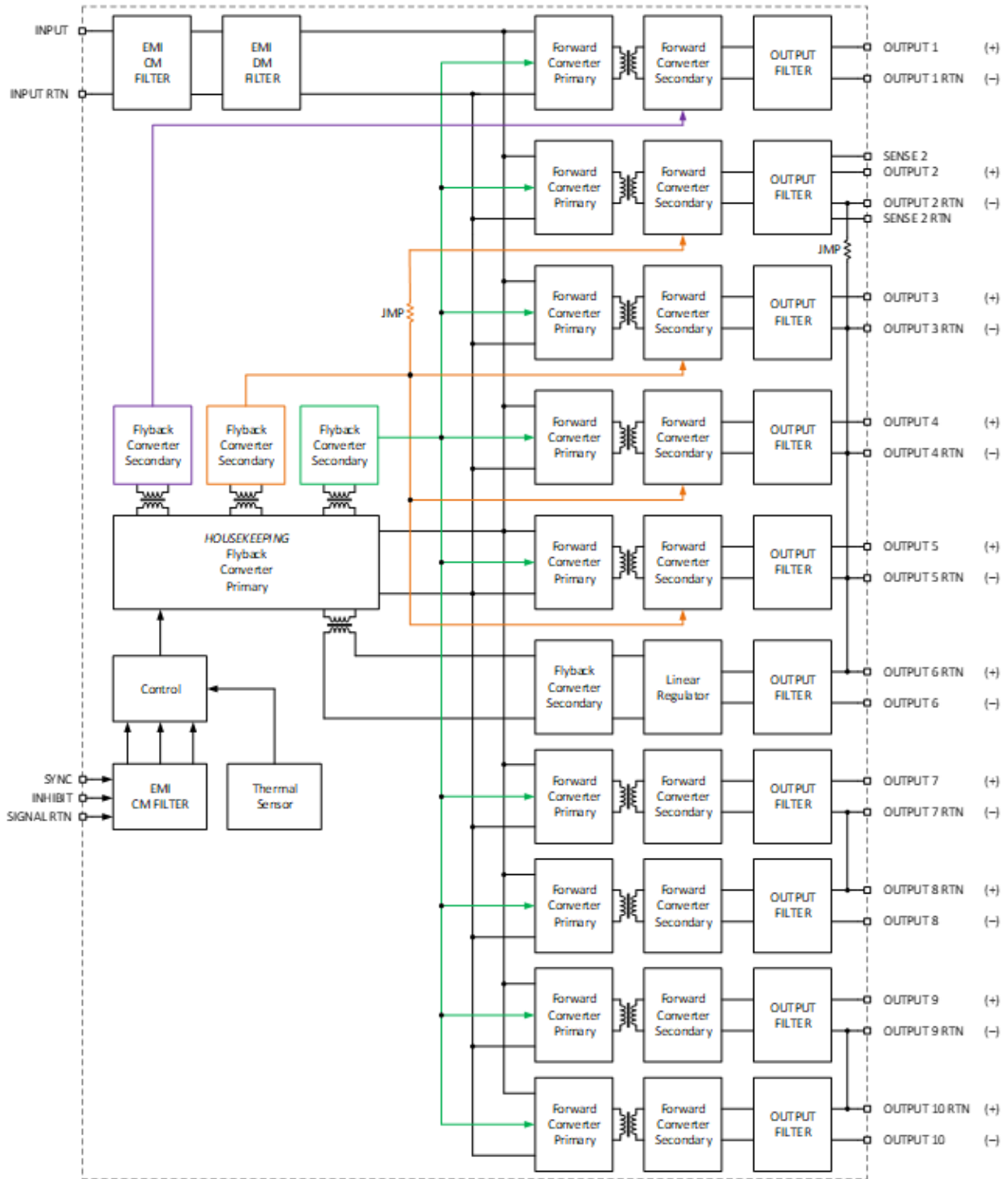

OUTPUTS CONFIGURATION RANGE TYPE A

Output #	Voltage Range	Current Range	Power Range
1	2.5 to 30 V _{DC}	0 to 4 A	0 to 10 W
2	2.5 to 50 V _{DC}	0 to 6 A	0 to 30 W
3	2.5 to 50 V _{DC}	0 to 9 A	0 to 40 W
4	1.1 to 5 V _{DC}	0 to 3 A	0 to 5 W
5	1.1 to 5 V _{DC}	0 to 3 A	0 to 5 W
6	-3.3 to -24 V _{DC}	0 to 0.4 A	0 to 5 W
7	2.5 to 50 V _{DC}	0 to 6 A	0 to 45 W
8	-2.5 to -50 V _{DC}	0 to 6 A	0 to 45 W
9	1.5 to 30 V _{DC}	0 to 3 A	0 to 10 W
10	-1.5 to -30 V _{DC}	0 to 3 A	0 to 10 W
Total			0 to 145 W

OPERATIONAL BLOCK DIAGRAM TYPE B

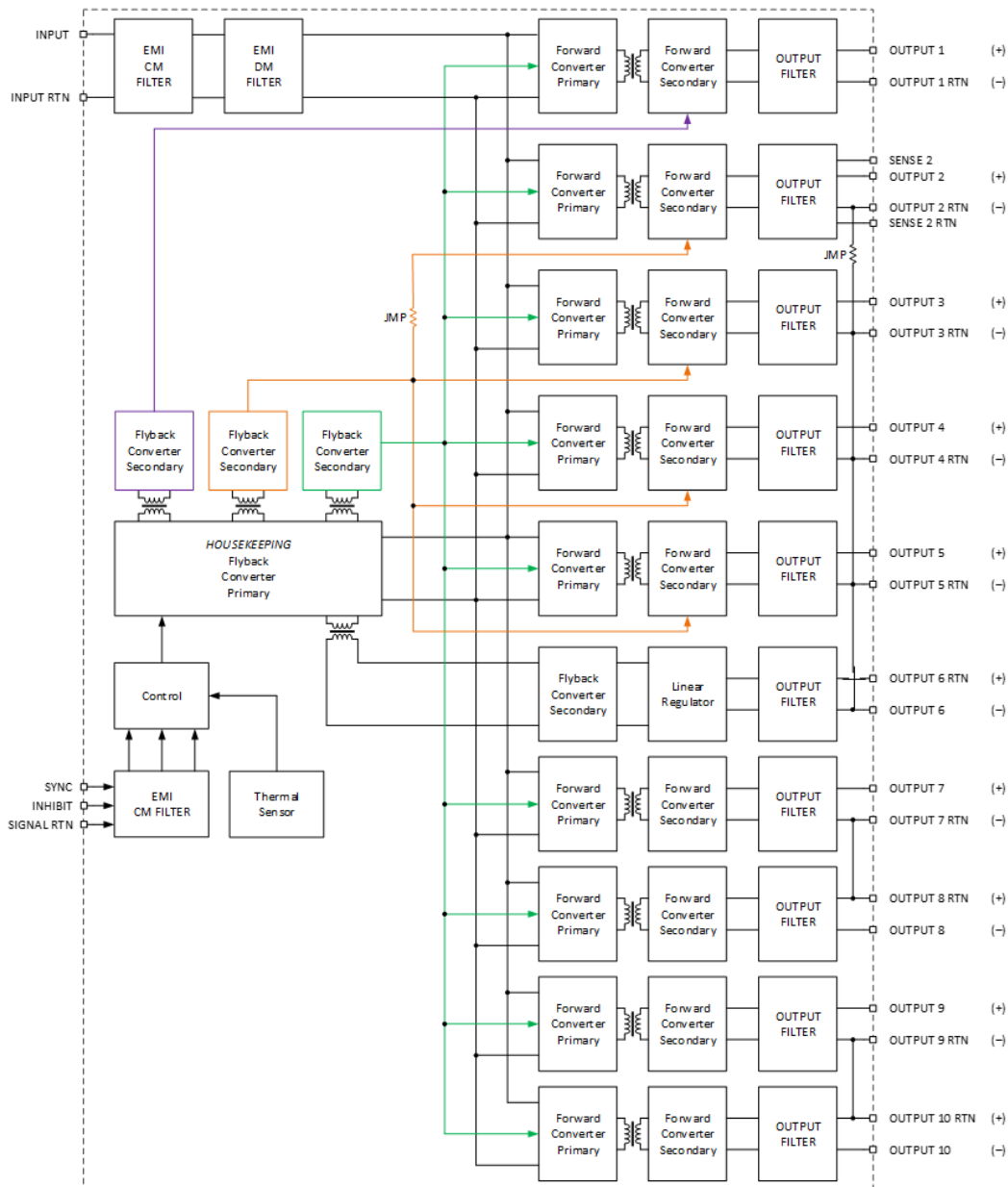

OUTPUTS CONFIGURATION RANGE TYPE B

Output #	Voltage Range	Current Range	Power Range
1	2.5 to 30 V _{DC}	0 to 4 A	0 to 10 W
2	2.5 to 50 V _{DC}	0 to 6 A	0 to 30 W
3	2.5 to 50 V _{DC}	0 to 9 A	0 to 40 W
4	1.1 to 5 V _{DC}	0 to 3 A	0 to 5 W
5	1.1 to 5 V _{DC}	0 to 3 A	0 to 5 W
6	3.3 to 24 V _{DC}	0 to 0.4 A	0 to 5 W
7	2.5 to 50 V _{DC}	0 to 6 A	0 to 45 W
8	-2.5 to -50 V _{DC}	0 to 6 A	0 to 45 W
9	1.5 to 30 V _{DC}	0 to 3 A	0 to 10 W
10	-1.5 to -30 V _{DC}	0 to 3 A	0 to 10 W
Total			0 to 145 W

OUTPUTS ISOLATION (GROUND RTN GROUPS)

- All outputs are isolated from the input.
- Outputs are separated into the following five galvanically isolated groups:
 - Group A: Output #1
 - Group B: Output #2 (must be connected to group C if output voltage is lower than 5V)
 - Group C: Outputs #3, #4, #5 and #6
 - Group D: Outputs #7 and #8
 - Group E: Outputs #9 and #10

PIN ASSIGNMENT: TYPE A

Connector type: M55302/61A44 or eq.

Mates with: M55302/62-A44M (solder cup termination) or M55302/66-44M (#22 AWG crimp termination) or eq.

Pin No.	Function	P	
1	OUT 4	+	●
2	OUT 3	+	○
3	OUT 3	+	○
4	OUT 3/4/5/6 RTN		●
5	OUT 3/4/5/6 RTN		●
6	OUT 3/4/5/6 RTN		●
7	OUT 2 RTN	-	●
8	OUT 2	+	○
9	OUT 6	-	●
10	OUT 5	+	●
11	INPUT RTN	-	●
12	INPUT RTN	-	●
13	INPUT	+	●
14	INPUT	+	●
15	OUT 8	-	●
16	OUT 7/8 RTN		●
17	OUT 7	+	●
18	OUT 9	+	●
19	OUT 9/10 RTN		●
20	OUT 10	-	●
21	OUT 1 RTN	-	●
22	OUT 1	+	●

Pin No.	Function	P	
23	OUT 4	+	●
24	OUT 3	+	○
25	OUT 3/4/5/6 RTN		●
26	OUT 3/4/5/6 RTN		●
27	OUT 3/4/5/6 RTN		●
28	OUT 2 RTN	-	●
29	OUT 2	+	○
30	SENSE 2	+	○
31	SENSE 2 RTN	-	○
32	OUT 5	+	●
33	INPUT RTN	-	●
34	INPUT RTN	-	●
35	INPUT	+	●
36	INPUT	+	●
37	OUT 8	-	●
38	OUT 7/8 RTN		●
39	OUT 7	+	●
40	INHIBIT	+	●
41	SYNC	+	●
42	SIGNAL RTN	-	●
43	OUT 1 RTN	-	●
44	OUT 1	+	●

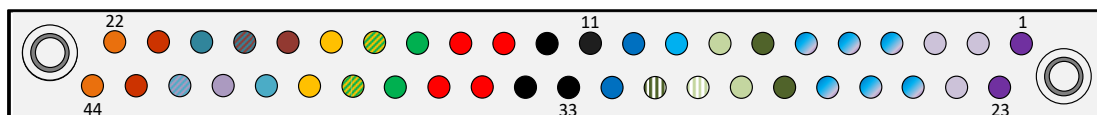

PIN ASSIGNMENT: TYPE B

Connector type: M55302/61A44 or eq.

Mates with: M55302/62-A44M (solder cup termination) or M55302/66-44M (#22 AWG crimp termination) or eq.

Pin No.	Function	P	
1	OUT 4	+	●
2	OUT 3	+	○
3	OUT 3	+	○
4	OUT 3/4/5 RTN – OUT 6		●
5	OUT 3/4/5 RTN – OUT 6		●
6	OUT 3/4/5/6 RTN		●
7	OUT 2 RTN	–	●
8	OUT 2	+	○
9	OUT 6	+	●
10	OUT 5	+	●
11	INPUT RTN	–	●
12	INPUT RTN	–	●
13	INPUT	+	●
14	INPUT	+	●
15	OUT 8	–	●
16	OUT 7/8 RTN		●
17	OUT 7	+	●
18	OUT 9	+	●
19	OUT 9/10 RTN		●
20	OUT 10	–	●
21	OUT 1 RTN	–	●
22	OUT 1	+	●

Pin No.	Function	P	
23	OUT 4	+	●
24	OUT 3	+	○
25	OUT 3/4/5 RTN – OUT 6		●
26	OUT 3/4/5 RTN – OUT 6		●
27	OUT 3/4/5 RTN – OUT 6		●
28	OUT 2 RTN	–	●
29	OUT 2	+	○
30	SENSE 2	+	○
31	SENSE 2 RTN	–	○
32	OUT 5	+	●
33	INPUT RTN	–	●
34	INPUT RTN	–	●
35	INPUT	+	●
36	INPUT	+	●
37	OUT 8	–	●
38	OUT 7/8 RTN		●
39	OUT 7	+	●
40	INHIBIT	+	●
41	SYNC	+	○
42	SIGNAL RTN	–	○
43	OUT 1 RTN	–	●
44	OUT 1	+	●

SIGNALS DESCRIPTION

SENSE 2 (pin 11)

The **SENSE 1** line is used to achieve accurate voltage regulation at load 1 terminals.

To use this feature, connect this pin directly to load 1's positive terminal.

If this function is not required, short **SENSE 2** to **OUT 2** (pins 8 and 29) as close as possible to the connector.

SENSE 2 RTN (pin 30)

The **SENSE 1 RTN** line is used to achieve accurate voltage regulation at load terminals.

To use this feature, connect this pin directly to load's negative terminal.

If this function is not required, short **SENSE 2 RTN** to **OUT 2 RTN** (pins 7 and 28) as close as possible to the connector.

Note: The use of remote sense has a limit of voltage dropout between the converter's output and the load's terminals of approximately 5% of nominal output voltage or 0.5 V – the lesser of the two.

INHIBIT (pin 40)

The **INHIBIT** signal is used to turn the power supply ON and OFF.

TTL "1" or OPEN – Power supply active (output turned on).

TTL "0" or SHORT to **SIGNAL RTN** – Power supply inhibited (output turned off).

If this function is not required, leave this pin unconnected.

This signal is referenced to **SIGNAL RTN** (pin 42)

SYNC (pin 41)

The **SYNC** signal is used to synchronize the power supply's switching frequency to system's clock.

Valid external clock frequency is 250 kHz \pm 10 kHz, and duty cycle is 50% \pm 10%.

If this function is not required, leave this pin unconnected - the power supply will use its internal clock.

This signal is referenced to **SIGNAL RTN** (pin 42)

SIGNAL RTN (pin 42)

Both **INHIBIT** and **SYNC** signals are referenced to this pin.

This pin is referenced to **INPUT RTN** (pins 11, 12, 33 and 34).

OUTLINE DRAWING

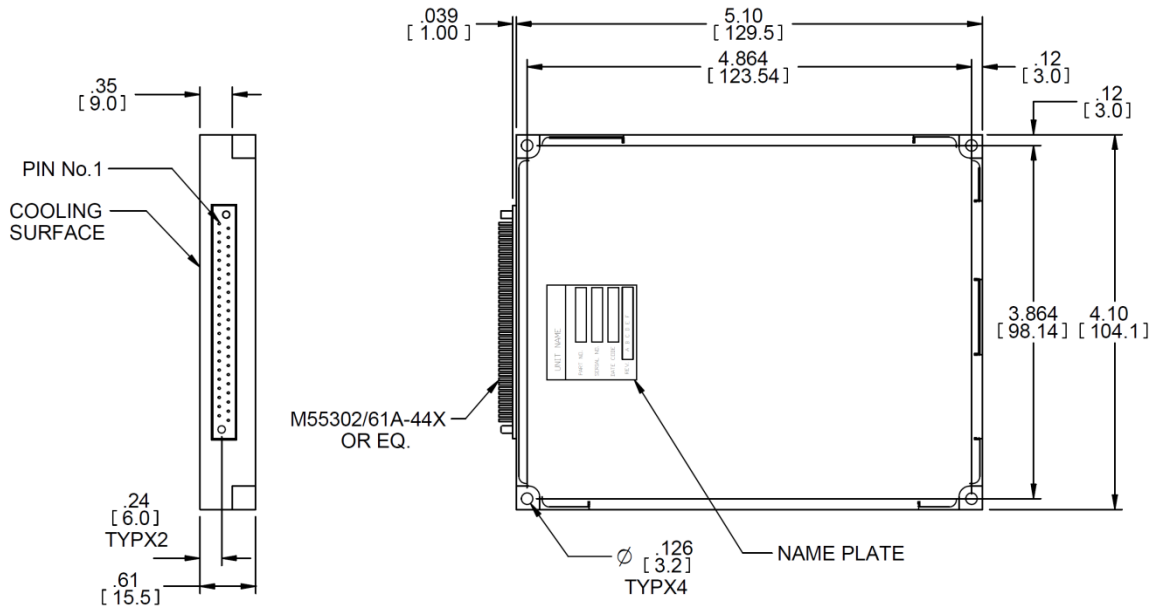

Notes

1. Dimensions are in inches [mm]
2. Tolerance is:
.XX ± .02 in
.XXX ± .01 in
3. Weight: 11.78 oz [334 g] ± 2%

HEAT DISSIPATION AREA

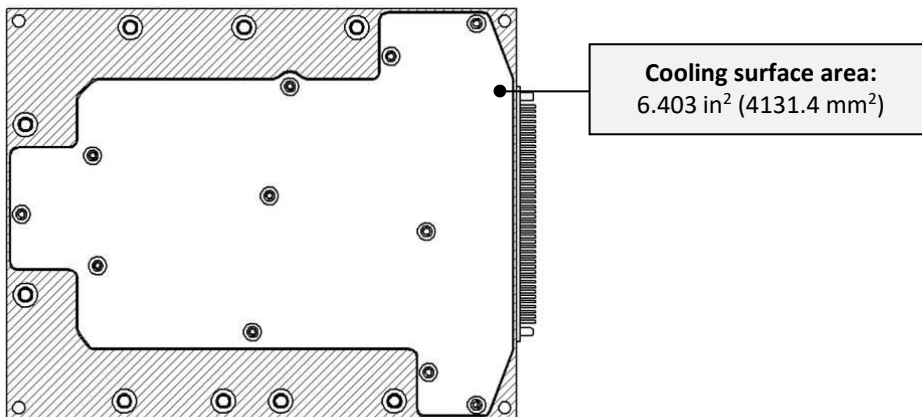

Note: Specifications are subject to change without prior notice by the manufacturer