

M916 SERIES

AC/DC POWER SUPPLY



PRODUCT HIGHLIGHTS

- SINGLE OUTPUT
- POWER FACTOR CORRECTED
- 1-PHASE AC/DC POWER SUPPLY
- UP TO 500 W



Applications

Military (Airborne, ground-fix, shipboard), Ruggedized, Telecom, Industrial Power Supply

Special Features

- High efficiency
- Wide input range
- High power factor (up to 0.98)
- Power density up to 14 W/in³
- Input / Output isolation
- Inrush current limiter
- Remote inhibit (on/off)
- Fixed switching freq. (250 kHz)
- External sync. capability
- EMI filters included
- Non-latching protections:
 - Overload/short-circuit
 - Input under-voltage lockout
 - Output over-voltage
 - Over temperature

Electrical Specifications

AC Input

Voltage range: 85 to 265 V_{AC},
50/60/400 Hz, single-phase

Output voltage regulation

Up to ±1%
(Low to high input line, no load to full load, -40 °C to +85 °C at baseplate).

Ripple and Noise

100-150mV_{p-p}, typical (max. 1%) without external capacitance. When connected to system capacitance ripple drops significantly.

DC Output

Voltage range: 3.3 to 300 V_{DC}
Current range: 0 to 50 A
Power range: 500 W

Efficiency

85% typical
(28V or 270V output, nominal input voltage, full load, room temperature)

Transient Over-and-undershoot

Current change from 50 to 100% output. Impedance change less than 50 to 250 mΩ depending on output voltage within 200 to 300 μs.

Isolation

Input to Output: 1000 V_{DC}
Input to Case: 1000 V_{DC}
Output to Case: 200 V_{DC}

EMC

Designed to meet* MIL-STD-461F
CE101, CE102, CS101, CS114, CS115, CS116, RE101, RE102, RS101, RS103

Turn-on Transient

No voltage overshoot at during power on.

* EMC Complies when tested with shielded cables and static resistive load. Depending on specific variant, a complementary input filter may be required for full compliance.

Protections †

Input

- **Inrush Current Limiter**
Initial input current surge to charge internal capacitances is limited internally.
- **Under Voltage Lock-Out**
Output shuts down when input voltage falls below $75 \pm 5 V_{AC}$.
Output turns on when input voltage rises above $85 \pm 5 V_{AC}$.

Output

- **Active Overvoltage Protection**
Secondary control shuts output down if output voltage exceeds nominal value by $10\% \pm 5\%$.
- **Passive Overvoltage Protection**
A transorb is placed across the output, selected $20\% \pm 10\%$ above nominal voltage.
- **Overload / Short-circuit**
If the load exceeds maximum current by $20\% \pm 10\%$, the protection mechanism causes the output to hiccup (turn off and on periodically at duty-cycle lower than 50%, until load is back within normal range).
CV/CC operation optional – **consult factory for details**

General

- **Over temperature protection**
Power supply shuts down if baseplate temperature exceeds $+105 \pm 5 \text{ }^\circ\text{C}$.
Resumes operation automatically upon cooldown to below $+95 \pm 5 \text{ }^\circ\text{C}$.

Environmental Conditions

Designed to meet MIL-STD-810F

Temperature

Methods 501.4 and 502.4
Operational: $-40 \text{ }^\circ\text{C}$ to $+85 \text{ }^\circ\text{C}$
(measured at base plate)
Storage: $-55 \text{ }^\circ\text{C}$ to $+125 \text{ }^\circ\text{C}$

Altitude

Method 500.4
Procedure I up to 70,000 ft.
Procedure II up to 40,000 ft.

Salt Fog

Method 509-4

Humidity

Method 507.4
Up to 95% RH

Vibration

Method 514.5
Procedure I
Category 24 - General minimum integrity exposure

Shock

Saw-tooth, 20 g peak, 11 ms

Reliability

150,000 hours, calculated IAW MIL-HDBK-217F Notice 2 at $+85 \text{ }^\circ\text{C}$ (at baseplate), Ground Fix conditions.

Environmental Stress Screening (ESS)

Including random vibration and thermal cycles is also available. **Please consult factory for details.**

† Thresholds and protections can be modified / removed – please consult factory

Pin Assignment

J1 - Input connector

Connector type: M24308/24-37F or eq.

Mates with: M24308/2-1F or eq.

Pin No.	Function		
1	NEUTRAL		●
2	NEUTRAL		●
3	N/C		

Pin No.	Function		
4	PHASE		●
5	PHASE		●
6	NEUTRAL		●

Pin No.	Function		
7	N/C		
8	N/C		
9	PHASE		●

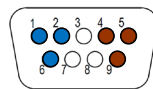

J2 - Output connector

Connector type: M24308/23-39F or eq.

Mates with: M24308/4-3F or eq.

LV option: Low voltage version (3.3 to 60 V_{DC})

Pin No.	Function		
1	SIGNAL RTN		●
2	SYNC		●
3	SENSE	+	●
4	VOUT	+	●
5	VOUT	+	●
6	VOUT	+	●
7	VOUT	+	●
8	VOUT	+	●
9	VOUT RTN	-	●
10	VOUT RTN	-	●

Pin No.	Function		
11	VOUT RTN	-	●
12	VOUT RTN	-	●
13	VOUT RTN	-	●
14	INHIBIT		●
15	SENSE RTN	-	●
16	VOUT	+	●
17	VOUT	+	●
18	VOUT	+	●
19	VOUT	+	●
20	VOUT	+	●

Pin No.	Function		
21	VOUT RTN	-	●
22	VOUT RTN	-	●
23	VOUT RTN	-	●
24	VOUT RTN	-	●
25	VOUT RTN	-	●

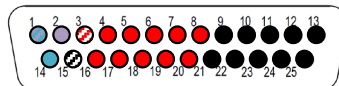

HV option: High voltage version (100 to 300 V_{DC})

Pin #	Function	P	
1	SIGNAL RTN	-	●
2	SYNC	+	●
3	BIT	+	●
4	N/C		
5	OUTPUT	+	●
6	OUTPUT	+	●
7	OUTPUT	+	●
8	N/C		
9	OUTPUT RTN	-	●
10	OUTPUT RTN	-	●

Pin #	Function	P	
11	OUTPUT RTN	-	●
12	OUTPUT RTN	-	●
13	OUTPUT RTN	-	●
14	INHIBIT		●
15	BIT RTN	-	●
16	N/C		
17	OUTPUT	+	●
18	OUTPUT	+	●
19	OUTPUT	+	●
20	OUTPUT	+	●

Pin #	Function	P	
21	OUTPUT	+	●
22	N/C		
23	OUTPUT RTN	-	●
24	OUTPUT RTN	-	●
25	OUTPUT RTN	-	●

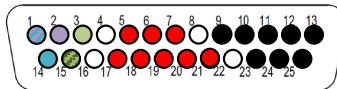

Note: All pins with identical designation/function should be connected together for best performance.

Typical Connection Diagram

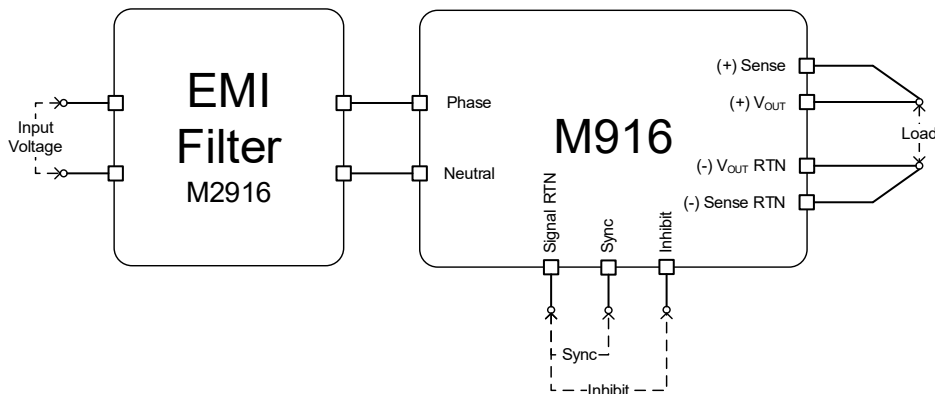

Functions and Signals

INHIBIT (connector J2, pin 14)

Description: The **INHIBIT** signal is used to turn the power supply ON and OFF.

Operation: Applying "1" or leaving open will turn the power supply ON. For constant operation, leave this pin unconnected.

Applying "0" or shorting this pin to its return line will turn the power supply OFF.

Signal Type: 5V TTL or dry contact (open/short).

Return line: This signal is referenced to **SIGNAL RTN** (connector J2, pin 1).

SYNC (connector J2, pin 2)

Description: The **SYNC** signal can be used to allow the power supply switching frequency to synchronize with a system clock.

Operation: Apply a square wave clock with frequency in the range of 250 kHz \pm 10 kHz and duty cycle of 50% \pm 10%, TTL level.

If not required, leave open. The power supply will work at 250 kHz \pm 10 kHz (internal clock).

Signal Type: 5V TTL

Return line: This signal is referenced to **SIGNAL RTN** (connector J2, pin 1).

SENSE (connector J2, pin 3) [**LOW VOLTAGE VERSION ONLY**]

Description: The **SENSE** measurement is used to compensate for voltage drop across the output wires by sensing the voltage at the load and correcting the increasing the output voltage accordingly, to provide the desired voltage at the load's terminals.

Operation: Connect the **SENSE** (connector J2, pin 3) to the positive load terminal, and the **SENSE RTN** (connector J2, pin 15) to the negative (return) load terminal.

The sense compensation is typically limited to 5% or 0.5V – the lesser of the two.

If not used, connect **SENSE** directly to **OUTPUT** pins, and the **SENSE RTN** pin directly to the **OUTPUT RTN** pins. **IMPORTANT: to avoid damage to the converter and/or the load - DO NOT LEAVE THE Sense/Sense RTN PINS UNCONNECTED.**

BIT (connector J2, pin 3) [**HIGH VOLTAGE VERSION ONLY**]

Description: The **BIT** signal indicates failure when one of the following occurs:

- Input voltage falls below $85 \pm 5 V_{rms}$ or rises above $255 \pm 5 V_{rms}$.
- Output voltage falls below Under-Voltage Limit threshold or rises above Over-Voltage Limit threshold for at least 100 ms.

Operation: This signal can be in one of two states:

Fail: Pins BIT and BIT RTN open

Good: Pins BIT and BIT RTN are shorted together through an internal phototransistor.

Signal Type: Opto-isolated open collector.

Polarity of externally applied voltage is (+) to BIT pin and (-) to BIT RTN pin.

Absolute maximum voltage allowable across pins BIT and BIT RTN: 30 V.

Absolute maximum current allowable through pins BIT and BIT RTN: 10 mA.

Return line: This signal is referenced to **BIT RTN** (connector J2, pin 15).

Outline Drawing

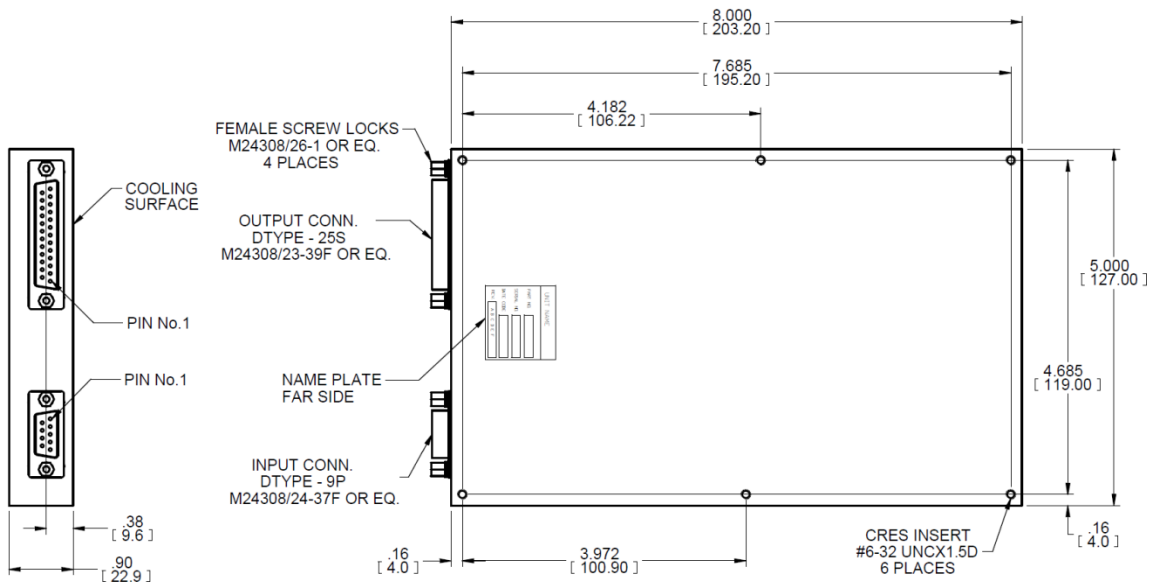

Notes

1. Dimensions are in inches [mm]
2. Tolerance is:
 .XX ± 0.01 in
 .XXX ± 0.008 in

Heat Dissipation Surface

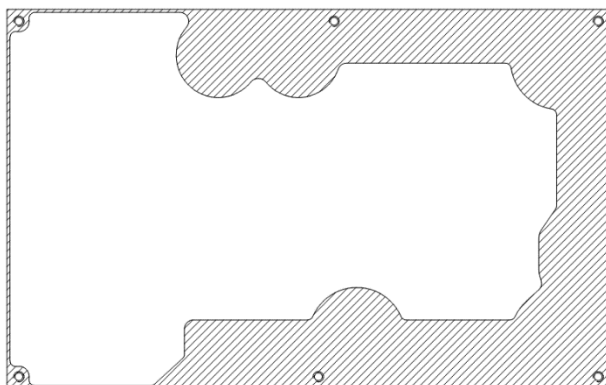

Dissipation Area
 13.9 in²
 (8,952 mm²)

Note: Specifications are subject to change without prior notice by the manufacturer

Standard Configurations

Part Number	Input	Output		J2 Pinout
	Voltage range	Voltage	Current	
M916-100	85 to 265 V _{AC} , 50/60/400 Hz, 1-phase	3.3 V _{DC}	35 A	LV option
M916-101	85 to 265 V _{AC} , 50/60/400 Hz, 1-phase	5 V _{DC}	35 A	LV option
M916-102	85 to 265 V _{AC} , 50/60/400 Hz, 1-phase	12 V _{DC}	35 A	LV option
M916-103	85 to 265 V _{AC} , 50/60/400 Hz, 1-phase	24 V _{DC}	20 A	LV option
M916-104	85 to 265 V _{AC} , 50/60/400 Hz, 1-phase	28 V _{DC}	18 A	LV option
M916-105	85 to 265 V _{AC} , 50/60/400 Hz, 1-phase	48 V _{DC}	10.5 A	LV option
M916-106	85 to 265 V _{AC} , 50/60/400 Hz, 1-phase	270 V _{DC}	1.85 A	HV option